

BASE RACK FITTING INSTRUCTION

Product Description: **BASE RACK – JOINED RACK**

WARNING

- ◆ The ARB BASE RACK system has a maximum capacity of 25kg per cross slat. Exceeding this limit may result in damage or failure
- ◆ This product must be installed exactly as per these instructions using only the hardware supplied
- ◆ This product or its fixing must not be modified in any way
- ◆ These instructions are correct as at the publication date
- ◆ Work safely at all times
- ◆ Unless otherwise instructed, tighten fasteners to specified torque
- ◆ Fastener torques are to be checked at regular intervals

ARB 4x4 ACCESSORIES

Corporate Head Office

www.arb.com.au

42-44 Garden St
Kilsyth, Victoria
AUSTRALIA 3137

Tel: +61 (3) 9761 6622
Fax: +61 (3) 9761 6807

Australian enquiries
North & South American enquiries
Other international enquiries

sales@arb.com.au
sales@arbusa.com
exports@arb.com.au



REQUIRED TOOLS FOR FITMENT OF PRODUCT:

T20 TORX DRIVER	T45 TORX DRIVER
------------------------	------------------------

FASTENER TORQUE SETTINGS:

SIZE	Torque Nm	Torque lbft
M6 – LOW HEAD	5Nm	3.5lbft
M8	22Nm	16lbft

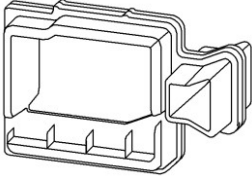
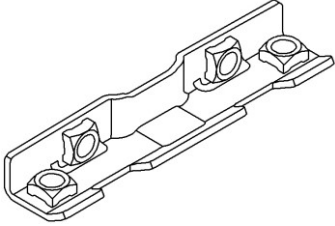
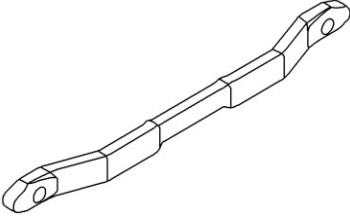
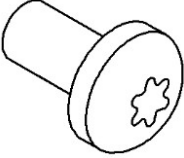
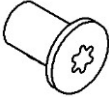
PARTS LISTING

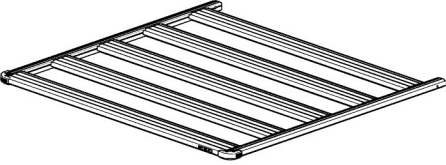
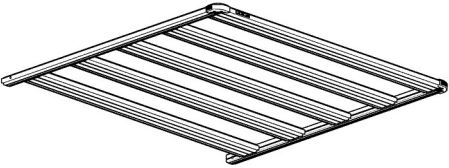
APPLICATION.	PART NO.	QTY	DESCRIPTION
	3163303	2	RACK JOINER RUBBER TRIM
	3753084	2	BRACKET BASE RACK JOINER MAIN
	3753084	2	BRACKET BASE RACK JOINER DOVETAIL FORGED
	6152060	8	SCREW PHD M8X16 TORX BLACK
	6152061	4	SCREW PHD M6x10 TORX BLACK LOW HEAD
	4584328	4	WASHER FLAT M8x19x1.2 LARGE
	4584359	4	WASHER FLAT M8x15x2 SMALL
	-	1	RACK SECTION "A"
	-	1	RACK SECTION "B"

FITTING PROCEDURE

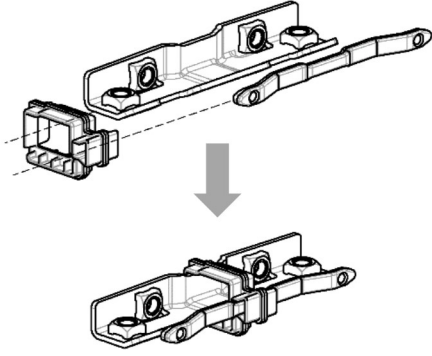

1. Insert the Brackets into the Rubber Trims as shown

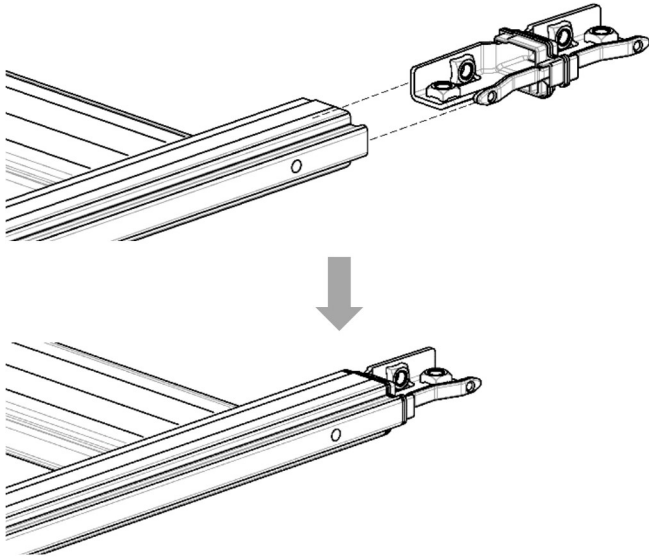

2. Insert the Brackets and Rubber Trim into one section of the rack as shown
3. Repeat on other side

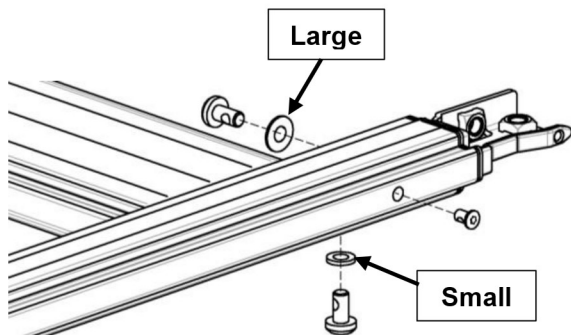
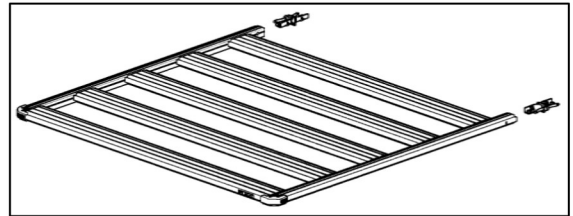

4. Loosely fit the fasteners
 - The M6 Screw fit through the hole in the dovetail
 - 1xM8 Screw and **small** washer on the **bottom** of the rack
 - 1xM8 Screw and **large** washer from the **inside face** of the rack
5. Repeat on other side

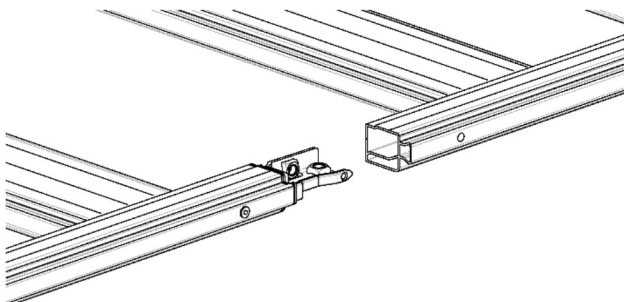

6. Push the other rack section over the Brackets and Rubber Trim

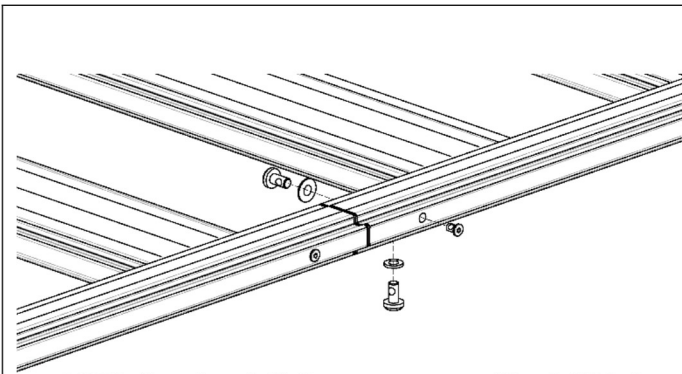

7. Loosely fit the fasteners
 - The M6 Screw fit through the hole in the dovetail
 - 1xM8 Screw and **small** washer on the **bottom** of the rack
 - 1xM8 Screw and **large** washer from the **inside face** of the rack
8. Repeat on other side

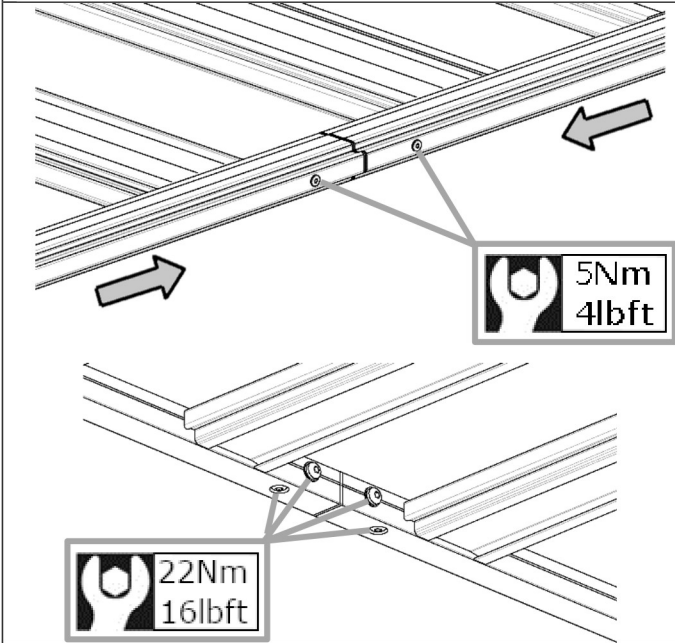

9. While pushing both rack sections together, tighten screws to specified torque

ARB BASE RACK